

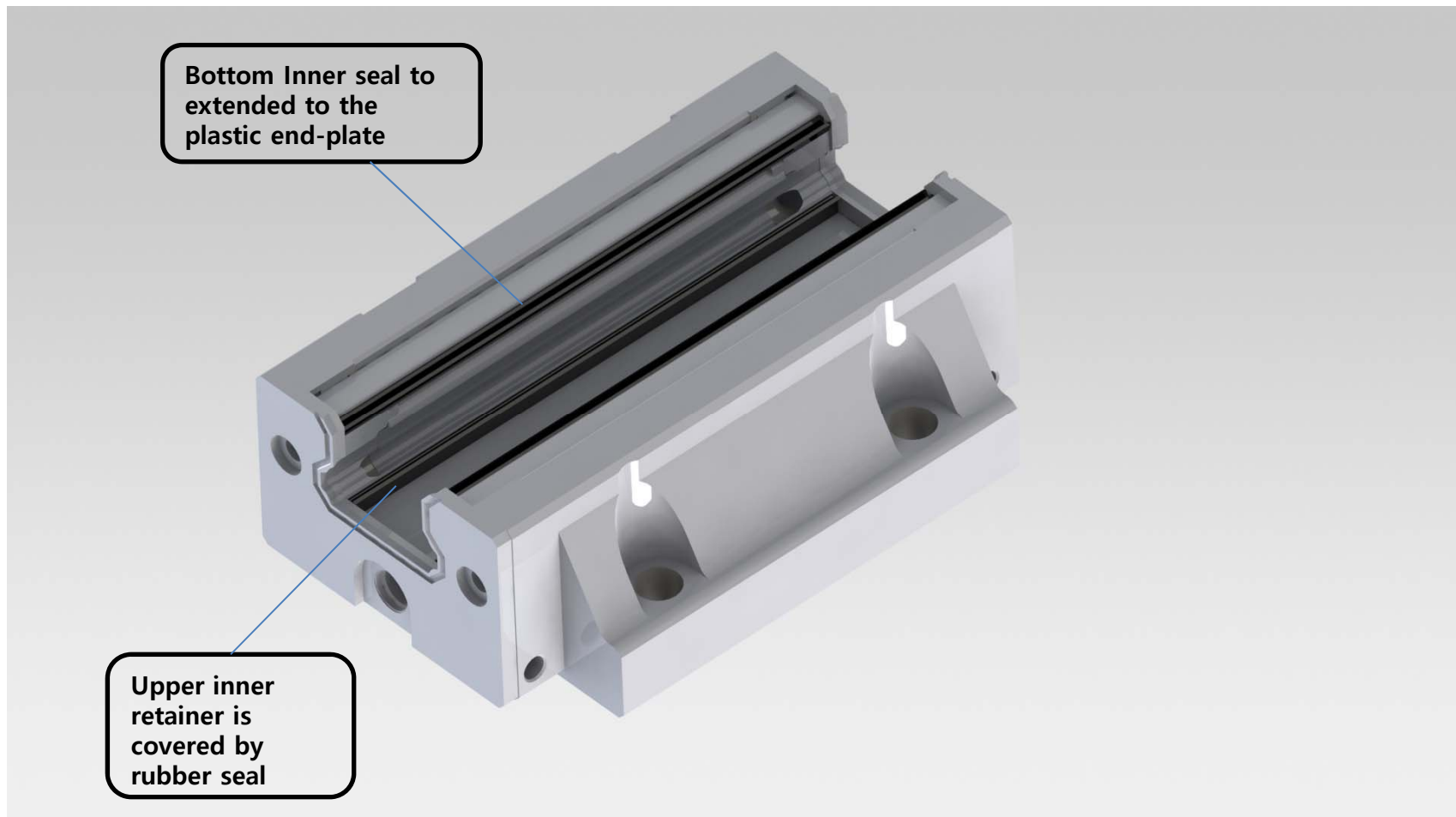

High Dust-proof seals

Features

1. Bottom Inner seals prevent dust or other foreign from entering into the LM system
2. Upper inner seals prevent dust or foreign from getting through inside of the bearing.



CONTAMINATION PROTECTION OPTION (1)

Double end-seals

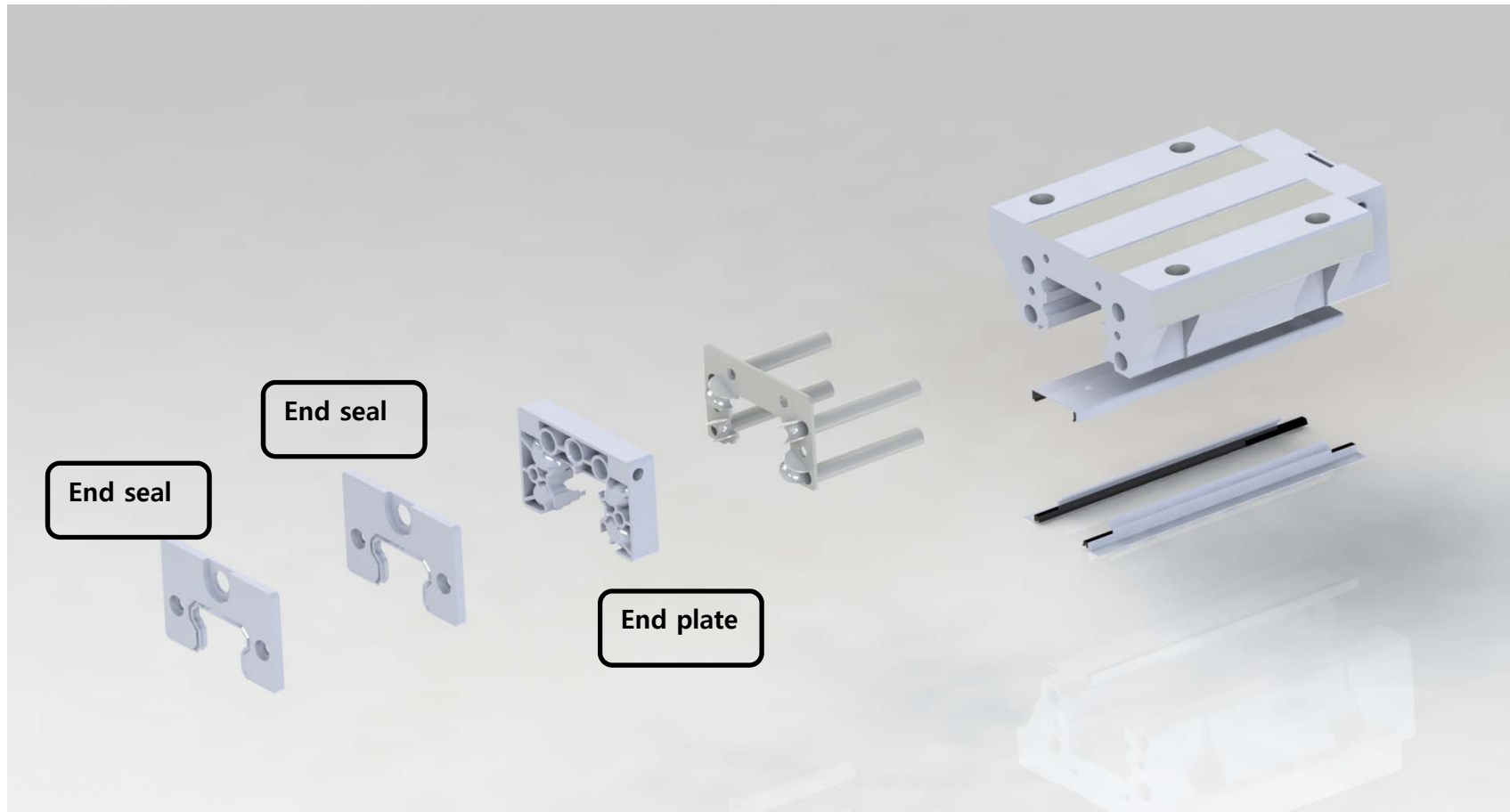

CONTAMINATION PROTECTION OPTION (3)

Dust free container (DF seal)

