

# BP – high ratio spiral bevel gear boxes

Solid and Hollow Shaft Design

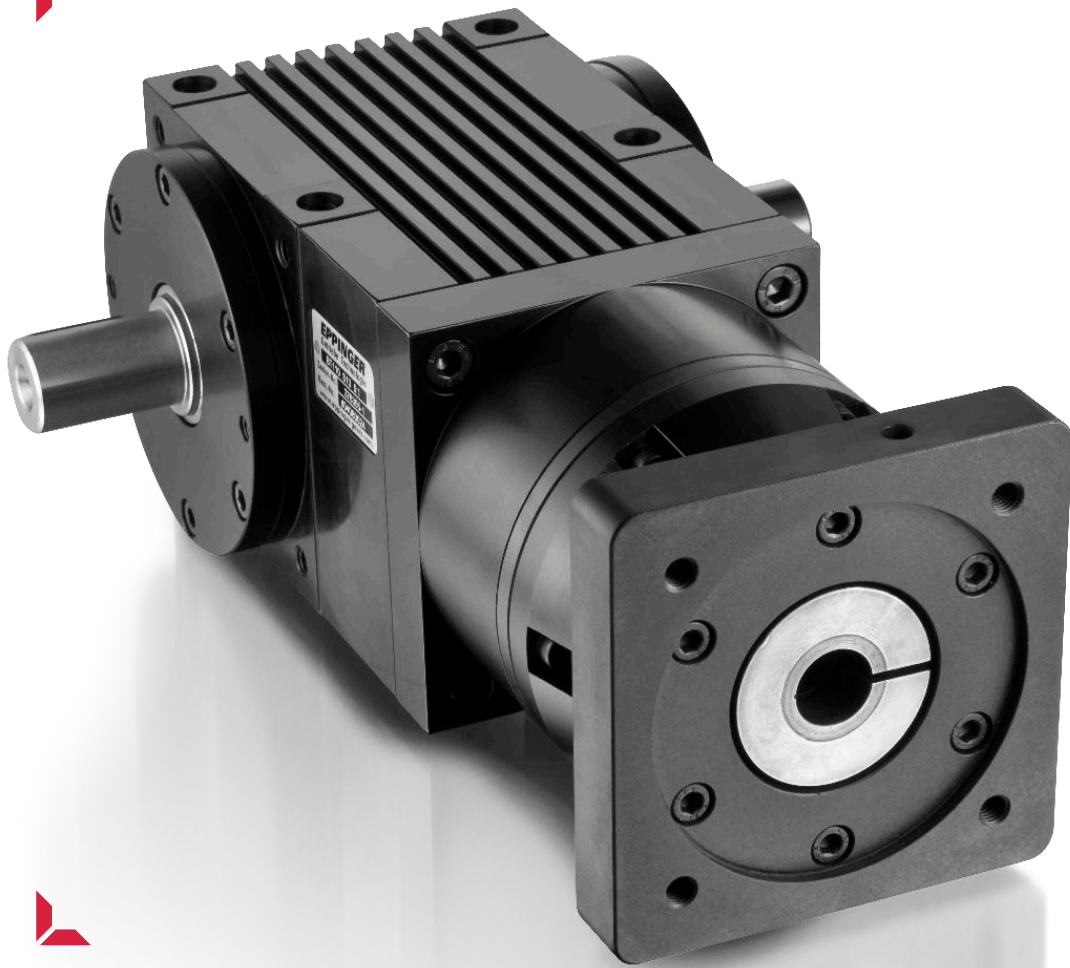

Cycloid gearboxes



Planetary gearboxes



Bevel gearboxes

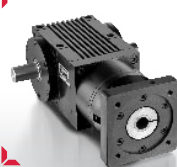

Planetary bevel gearboxes



Hypoid gearboxes



Gear technology

# EPPINGER planetary bevel gear boxes

The planetary bevel gear boxes of the BP series are based on a pre-fabricated and specifically matched combination of BT series bevel gear boxes with pre-stages from the planetary gear boxes of the PE series. The BT series is distinguished by especially high power density and variability. Maximum precision of the axes and bearing seats, combined with Gleason bevel gearing to take high loads, are the basis for minimized tooth clearance and optimal transmission properties. With the combination of hardened and ground gear teeth with high precision gear components, the PE series guarantees efficient performance, smooth running and high uptime.

The innovative solutions allow for a host of application options. Hence, the variability of the upstream planetary stages covers a wide spectrum of gear box ratios and offers extremely high ratios up to  $i = 320 : 1$ , while at the same time maintaining high efficiency levels.

Constant backlash control is guaranteed by the highly stable design of the housing and the hardened, super-finished gear components. Best efficiency rates ensure high energy efficiency and add to cost reductions.

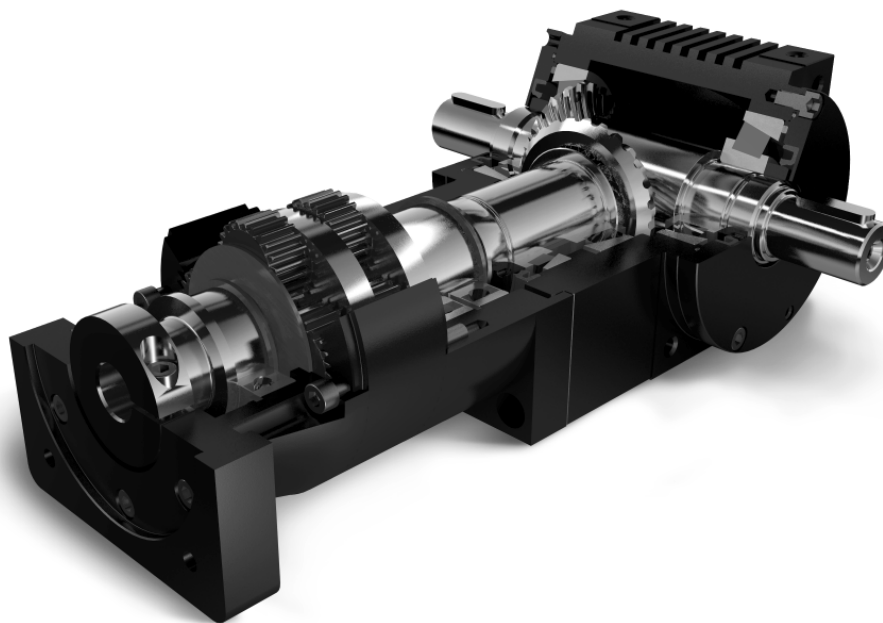

## FEATURES AND BENEFITS OF THE PLANETARY BEVEL GEAR BOX SERIES

- extremely high transmission ratios can be realized
- ground gears in the planetary pre-stage
- convincing transmission quality and smooth running
- considerable output torque
- high level of efficiency
- constant backlash control
- optional installation position
- easy mounting of a wide range of motors

Our product range includes besides **bevel-, hypoid-, planetary- and cycloidal gear boxes** also **special customized gear boxes and high precision gear technology**. With our **gear motors and integrated combinations of our gear box series** we extended our portfolio.

## Performance data

	Abbreviation	Unit	Ratio	BP075	BP090	BP110	BP140	BP170	BP210	BP240	BP280	Number of stages
Nominal output torque	T2N	Nm	i = 7.5 : 1	50	85	165	370	600	In process of planning			2
			i = 10 : 1	45	70	165	340	555				
			i = 12 : 1	24	48	105	225	337				
			i = 15 : 1	37	58	132	278	460				
			i = 16 : 1	32	64	140	240	450				
			i = 20 : 1	30	55	110	235	395				
			i = 25 : 1	28	44	92	202	330				
			i = 32 : 1	28	55	110	235	395				
			i = 40 : 1	25	45	90	210	335				
			i = 50 : 1	45	70	165	340	555				
			i = 60 : 1	37	72	135	370	480				
			i = 64 : 1	45	70	165	340	555				
			i = 75 : 1	37	58	132	278	460				
			i = 80 : 1	45	70	165	340	555				
			i = 100 : 1	30	55	110	235	395				
			i = 120 : 1	37	58	132	278	460				
			i = 160 : 1	30	55	110	235	395				
			i = 180 : 1	28	44	92	202	303				
			i = 200 : 1	28	44	92	202	303				
			i = 256 : 1	30	55	110	235	395				
i = 320 : 1	28	44	92	202	330							
Max. output torque	T2B	Nm	For all i	1.5 times nominal output drive torque (approved for 30000 cycles)								
Emergency off torque	T2Not	Nm		2 times nominal output drive torque (limited to 1000 cycles / service life)								
Max. input speed	n1	rpm		3000	2500	2200	2100	1900				
Backlash output shaft standard		arcmin		<19	<19	<17	<16	<16		2 3		
Backlash output shaft precision		arcmin		<12	<10	<10	<9	<9		2 3		
Permissible radial load on the drive shaft	FR2max*	N		1100	1600	2600	4600	6000		For all i		
Permissible axial load on the drive shaft *related to center of shaft journal	FA2max*	N		600	800	1300	2300	3000				
Efficiency at nominal load		%		94% 92%						2 3		
Operating noise measured at a distance of 1m (at input speed n1 ≈ 1.500 rpm)	Lpa	db(A)		73	75	78	78	79		For all i		
Service life	Lh	h		> 15,000						For all i		
Lubrication			Planetary gear box lubricated with grease / bevel gear box with synth. oil, ISO VG 150									
Motor flange			Optional - according to DIN Standard									

## Thermal limit rating

	Abbreviation	Unit	BP075	BP090	BP110	BP140	BP170	BP210	BP240	BP280	
Thermal limit rating** <small>**at T2N, i = 5:1, RT=20°C and ED = 100%</small>	Ptherm	kW	3.5	4.8	7.0	10.5	15.0				
Definition: the thermal limit rating Ptherm is the transferable output during continuous operation at a max. permissible oil bath temperature of 90 °C.  Ptherm, effective < Ptherm, permissible			Drive speed [rpm] correction factor K1				0.4*n1N 1.0	0.7*n1N 0.8	n1N 0.5		
			Duty cycle ED [%] Correction factor K2				100 1.0	80 1.2	60 1.4	40 1.6	20 1.8
Example:	Gear box	Revolution speed	ED	Ambient		Ambient temperature [°C] correction factor K3					
Permissible thermal limit rating at:	BP110 5:1	560 rpm	60%	40°C		10 1.20	20 1.00	30 0.83	40 0.70	50 0.60	
Ptherm, permissible = Ptherm (BP110) x K1 x K2 x K3 = 7.0 kW x 1.0 x 1.4 x 0.7 = 6.86 kW											

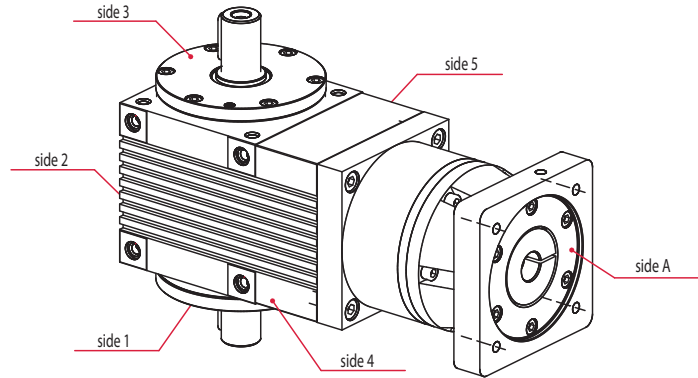
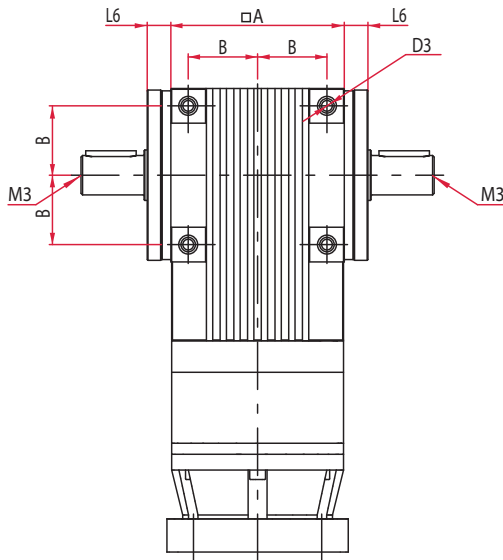
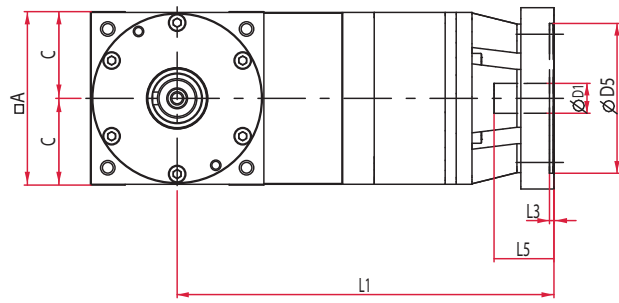
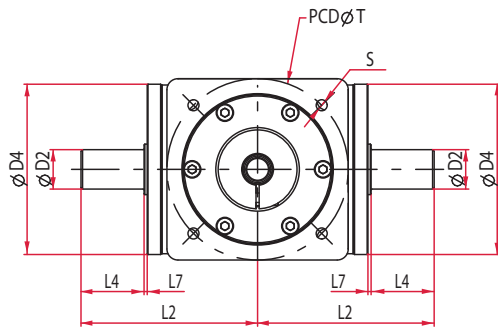

### Solid Shaft Design (dimensions in mm)

	BP075	BP090	BP110	BP140	BP170
□ A	75	90	110	140	170
B	30	36	44	55	67
C	37.5	45	55	70	85
Ø D1	14 H7	14 H7	19 H7	24 H7	28 H7
Ø D2	18 k6	20 k6	25 k6	32 k6	40 k6
Ø D4	73 h7	88 h7	108 h7	135 h7	165 h7
Ø D5	40 g6	80 g6	95 g6	130 g6	130 g6
L1 single stage	169	202	242	288	348
L1 2-stage	181	225	268	325	385
L2	84	97	112	140	162
L3	3	3	3.5	4	4
L4	30	35	40	50	60
L5	30	30	40	50	60
L6	14.5	15	15	18	15
L7	2	2	2	2	2
ØT	63	100	115	130	165
s	M5x12	M6x15	M8x20	M10x24	M10x24
D3	M5x10	M6x12	M8x16	M10x20	M10x24
KeyD2	6x6x25	6x6x28	8x7x32	10x8x45	12x8x50
M3*	M6	M8	M10	M16	M16

\* Thread in shaft end acc. to form DS, DIN 332

### Hollow Shaft Design

Dimensions of the bevel gear Hollow Shaft Design are given in the product sheet for the BT gear box series

